

17th International Cognitive Linguistics Conference

Buenos Aires, Argentina - July 17, 2025

Discourse Connectives as Constructions:

Developments in Conceptual Domains and Properties as Linguistic Units

Yoichiro Hasebe

Doshisha University

yhasebe@mail.doshisha.ac.jp



What are Discourse Connectives?

Discourse connectives:

Elements that connect discourse segments beyond sentence level (Hasebe 2021)

Also called: discourse markers (Schiffrin 1987; Fraser 1999), discourse operators (Redeker 1990), pragmatic markers (Brinton 1996), discourse structuring markers (Traugott 2022)

Examples by type:

- **Causal:** *so, because, therefore, since, consequently*
- **Adversative:** *but, instead, however, although, nevertheless*
- **Elaborative:** *in fact, actually, indeed, in other words*

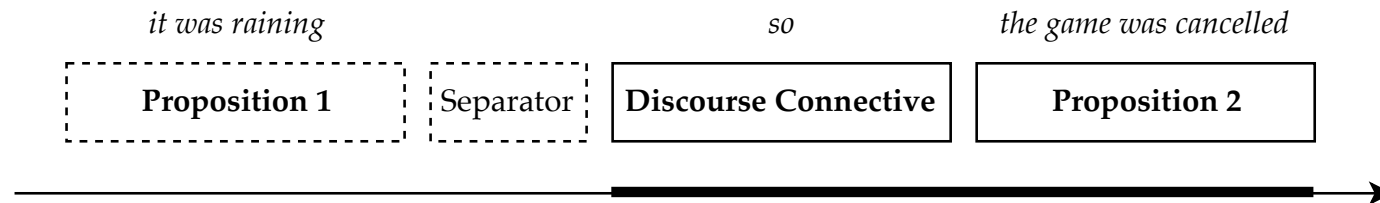

Research Question:

How do discourse connectives function as constructions within the Construction Grammar framework?

Theoretical Background

Construction Grammar tradition

- Form-meaning pairings (Goldberg 1995, 2006)
- Discourse as construction (emerging research area)

Related Work

- Groom (2019): Discourse-constructional approaches
- Traugott (2022): Historical development of DSMs

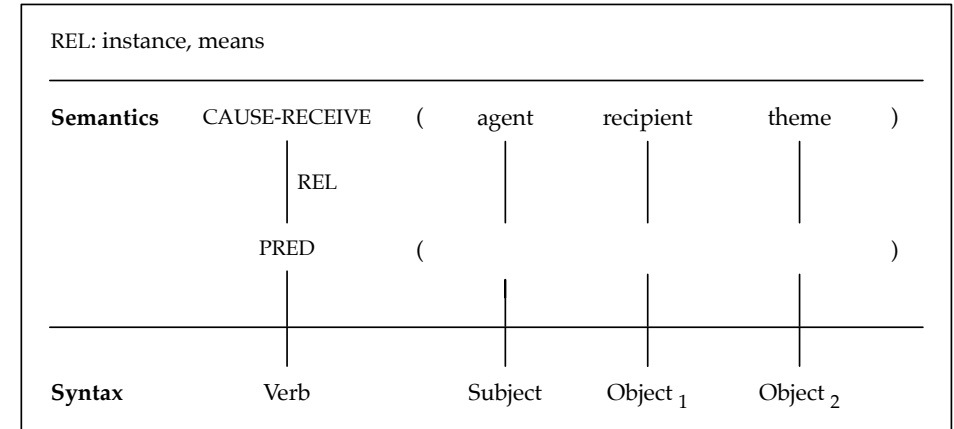

Our Approach

- Discourse connectives as full-fledged constructions (not just markers)
- Current Discourse Space (CDS) as dynamic context (Langacker 2008)
- Integration of three conceptual domains (Sweetser 1990)
- Monadic framework capturing *idempotent* discourse operations

Three Conceptual Domains

Following Sweetser (1990), discourse connectives operate across three conceptual domains:

1. Content Domain

- Real-world events/states
- Physical relationships
- Real-world causation

2. Epistemic Domain

- Reasoning and knowledge
- Inference from evidence
- Mental processes

3. Speech-act Domain

- Performative aspects
- Discourse strategies
- Justification for utterances

Modal *may*

- a. Content: John *may* go. (permission)
- b. Epistemic: John *may* be there. (possibility)
- c. Speech-act: *May* I ask...? (politeness)

Conditional *if*

- a. Content: *If* you heat water, it boils. (physical causation)
- b. Epistemic: *If* he's late, he must be stuck in traffic. (reasoning)
- c. Speech-act: *If* I may say so, that's wrong. (politeness marker)

→ **Same domains at sentence & discourse levels**

Discourse-Connective Construction (DCC)

Definition: A grammatical construction that links propositions across sentence boundaries through domain-specific type constraints

Processing mechanism

1. Type-constrained retrieval of $PROP_1$ from CDS
2. Introduction of $PROP_2$ with specified relation
3. Update of discourse context ($CDS_{in} \rightarrow CDS_{out}$)

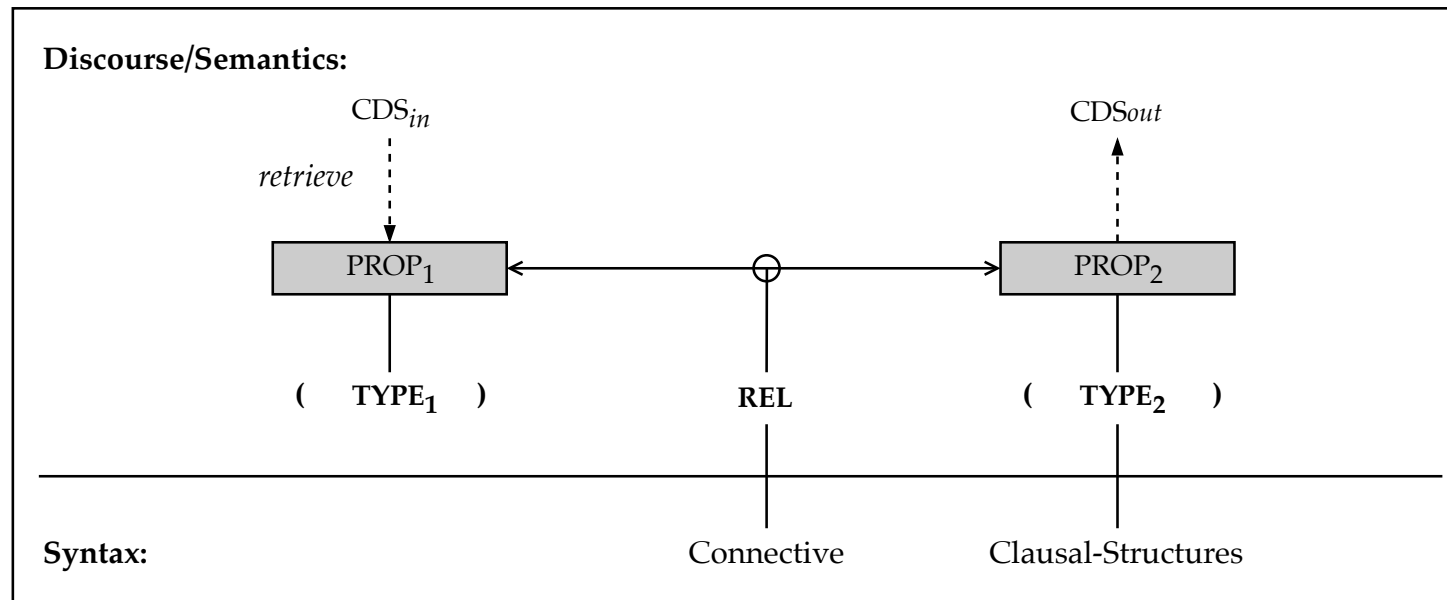

Key Components in DCC

- **Current Discourse Space (CDS)** : “A mental space comprising everything presumed to be shared by speaker and hearer at a given moment” (Langacker 2008)
- **REL**: The relational function designated by specific connective (e.g., causation for *because*, contrast for *instead*, elaboration for *in fact*)
- **TYPE₁**: Constraint on the first proposition (what must be retrieved from context)
- **TYPE₂**: Constraint on the second proposition (what the connective introduces)

Note "Proposition" here refers to relational conceptual structures in Langacker's (2008) sense, not truth-conditional statements

Because Construction Configuration

Type specification

Because: REL (PROP₁: result/consequence, PROP₂: cause/base)

Processing pattern

1. PROP₁ (result/consequence) is retrieved from CDS_{in}
2. *Because* introduces PROP₂ (cause/base)
3. Context is updated from CDS_{in} to CDS_{out} with causal relation

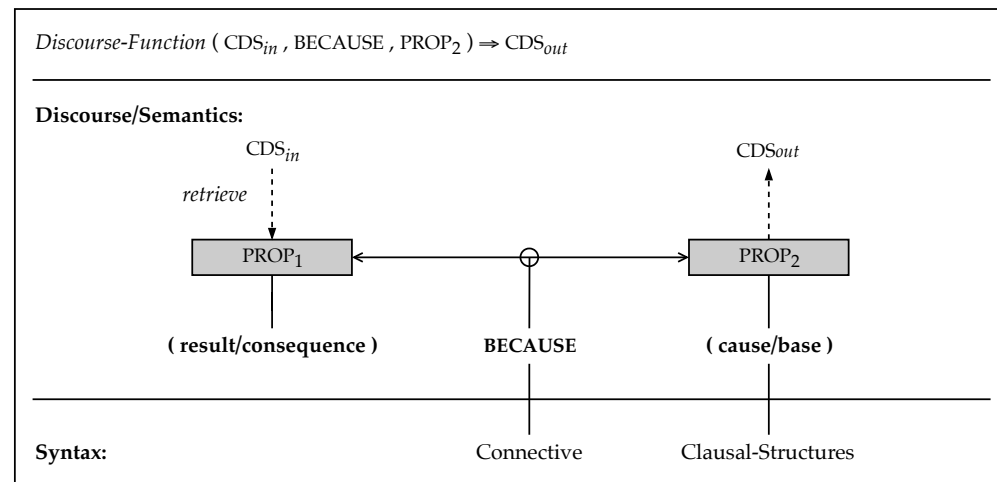

Note If types are reversed (PROP₁: cause, PROP₂: result), different DCCs emerge (e.g., *so, therefore*)

Because in Three Domains

Content-domain causation

(1) I get very emotional when I remember him *because* he was killed later in combat

[[TCSE 2126 | Jose Miguel Sokoloff](#)] (Real-world cause → effect)



Epistemic-domain causation

(2) This satellite covers the whole of Africa ... and that's important, *because* if you know how many times a place has had a drought in the last 30 years, you can make a pretty good estimate what the chances are of drought in the future... [[TCSE 2065 | Rose Goslinga](#)] (Evidence → conclusion)



Speech-act-domain causation

(3) Raise your hands if you've read Don Quixote... good, *because* I need somebody smart here

[[TCSE 2027 | David Kwong](#)] (Justifies the speech act of asking)



Instead Construction Configuration

Type specification

Instead: REL($PROP_1$: reference::neg, $PROP_2$: alternative)

Processing pattern

1. $PROP_1$ (reference-statement) must be negatable
2. *Instead* introduces $PROP_2$ (alternative-statement)
3. Focus shifts from $PROP_1$ to $PROP_2$ as alternative

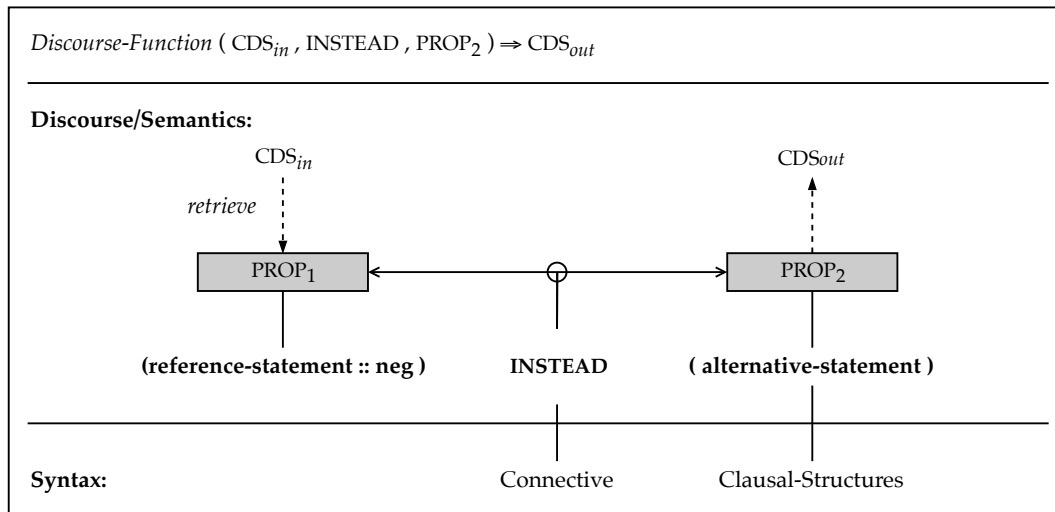

Note Epistemic perspective inherent in adversative relations

Instead in Three Domains

Content-domain alternatives

- (4) You're not actually doing four or five things at once... *Instead*, you're rapidly shifting from one thing to the next [[TCSE 2834 | Manoush Zomorodi](#)] (What actually occurs, not what one thinks)



Epistemic-domain alternatives

- (5) Most people think that new technology can never start in Africa. *Instead*, they think that the best way to help the continent advance is by providing aid or services...
[[TCSE 3694 | Keller Rinaudo](#)] (Alternative belief/conception)



Speech-act-domain alternatives

- (6) Don't treat it like a game and don't treat it like a resume review. *Instead*, use it to source and qualify leads... [[TCSE 20083 | Christina Wallace](#)] (Alternative directive/imperative)



In fact Construction Configuration

Type specification

In fact: REL($PROP_1$: reference, $PROP_2$: evidence::new)

Processing pattern

1. $PROP_1$ serves as reference-statement
2. *In fact* introduces $PROP_2$ as evidence/support (new information)
3. Strengthening effect through scalar implicature

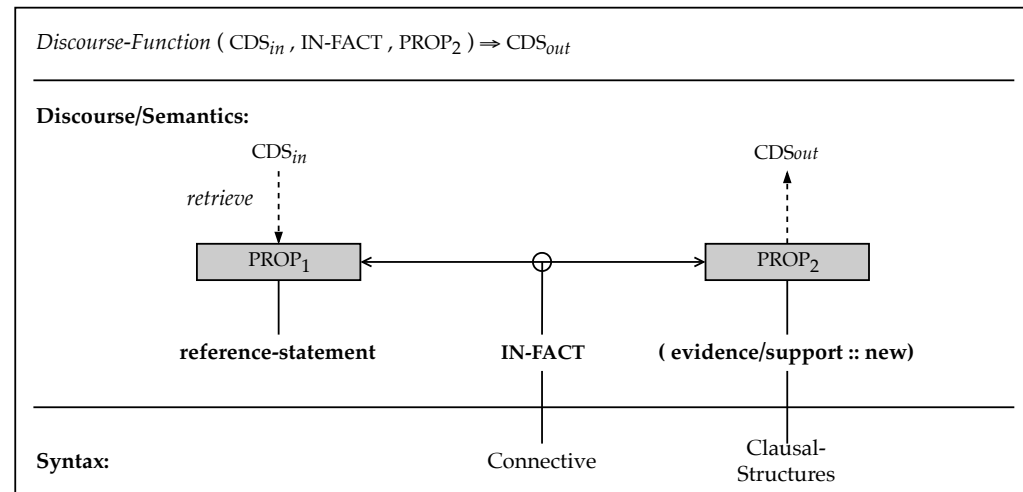

Note Speech-act perspective inherent in elaborative relations - strengthening prior utterance

In Fact for Elaboration

External Evidence:



(7) (Movies affect people's choices...) *In fact*, studies show that the movies you watch affect your career choices, emotions... [[TCSE 2890 | Naomi McDougall Jones](#)] (Scientific evidence as new support)

Personal/Direct Evidence:

(8) I'm a first-generation American... *In fact*, my father Gabriel came to the US almost 50 years ago [[TCSE 15284 | Michael Rain](#)] (Personal specifics strengthen general claim)



Scalar/Surprising Evidence:

(9) Birds love and date like humans. In fact, you'll be surprised to know that males dress to impress [[TCSE 3590 | Washington Wachira](#)] (Unexpected detail as elaboration)

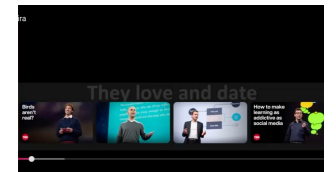

Monadic Structure of Discourse

How to formalize discourse operations?

Precedents in Cognitive Linguistics:

- Metaphor theory: Domain mappings as functions (Lakoff & Johnson)
- Mental Space theory: Domain projections and blending (Fauconnier & Turner)
- Construction Grammar: Class hierarchies and inheritance (Fillmore, Goldberg)

The monadic approach:

- Captures idempotent nature: CDS → CDS
- Preserves flat structure (vs. sentence-level recursion)
- Enables indefinite continuation

Three fundamental operations:

- *Unit, Map, and Join*

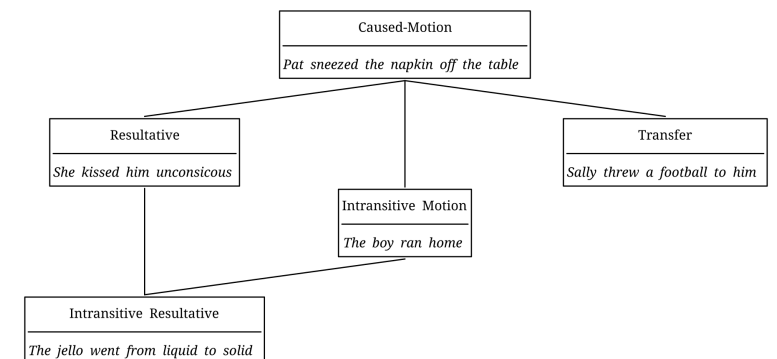
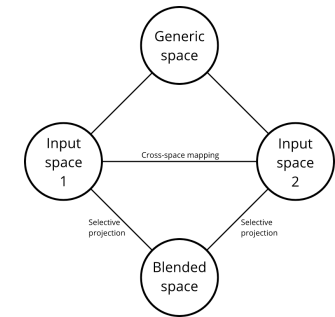
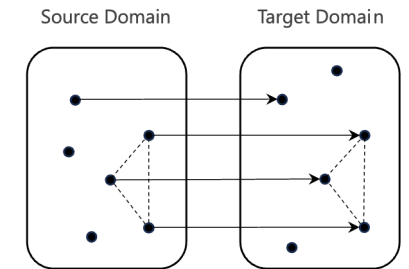

Unit: Creating Discourse from Nothing

The *unit* operation ($\emptyset \rightarrow \text{CDS}$)

- Wraps initial content into discourse context
- Any meaningful utterance constitutes discourse by itself
- Speaker's first utterance creates the initial CDS
- Establishes shared ground between interlocutors

In discourse terms . . .

- Converts raw propositions into contextually embedded information
- Creates the foundation for subsequent discourse operations
- Enables tracking of discourse history and common ground

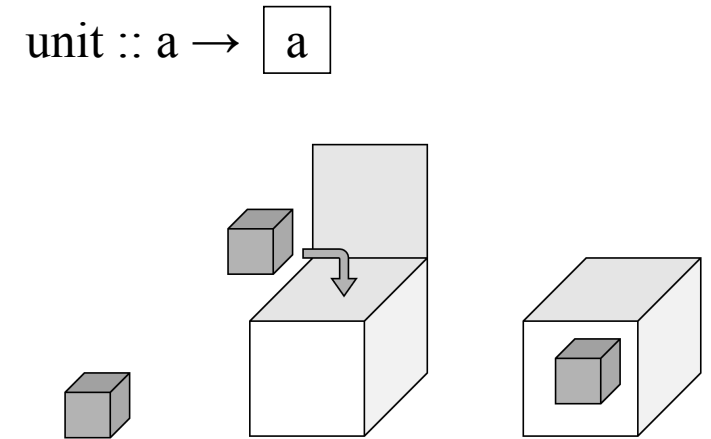

Map: Developing Discourse Content

The *map* operation (CDS → CDS)

- Develops content while preserving discourse structure
- Each utterance updates CDS with new properties
- Properties remain accessible within CDS structure
- Maintains discourse coherence through structured updates

$\text{map} :: (a \rightarrow b) \rightarrow (\boxed{a} \rightarrow \boxed{b})$

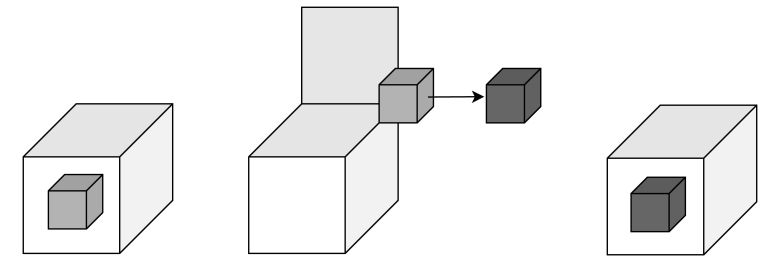

In discourse terms . . .

- Discourse connectives trigger map operations
- Proposition retrieval extracts and develops content
- Context is enriched without losing previous information
- Ensures continuity of discourse flow

Note Map can simultaneously create and update context - as when "so" initiates a conversation by presupposing prior shared understanding

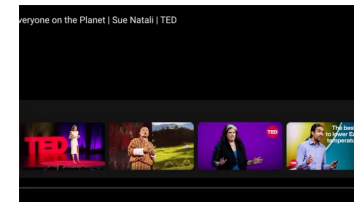

So whenever I tell people I'm an Arctic scientist, ...

Join: Preventing Structural Explosion

The *join* operation ($\text{CDS}[\text{CDS}[\dots]] \rightarrow \text{CDS}$)

- Flattens nested discourse structures
- Without flattening: exponential growth of complexity
- Enables unlimited discourse continuation

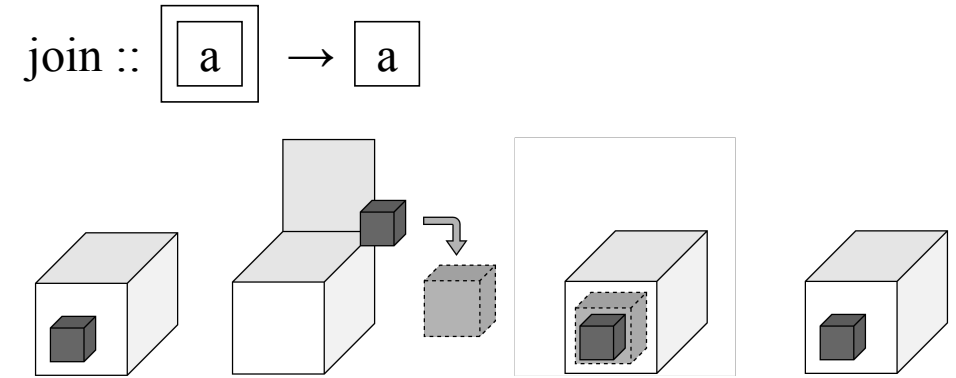

In discourse terms . . .

- Resolves multiple levels of embedding
- Maintains single-level discourse representation while handling complex internal structures
- Prevents cognitive overload from nested contexts
- Handles reported speech, hypotheticals, embedded narratives

Conclusion

Summary of key points:

- Discourse connectives as full-fledged constructions (DCCs) with type specifications
- Type constraints distinguish connectives (e.g., *because* vs. *so*)
- Three domains operate at both sentence and discourse levels → justifies construction analysis
- Idempotent property: $CDS \rightarrow CDS$ (vs. recursive sentence-level constructions)
- *Unit, map, join* are not ad hoc concepts but established monadic operations from category theory
- These formal operations naturally capture discourse processing patterns

Future directions:

- Cross-linguistic validation of the framework
- Computational implementation of monadic CDS model (cf. Hasebe 2023)
- Real-time language processing and discourse comprehension (cf. Hasebe & Lee forthcoming)

References

- Brinton, L. J. (1996). *Pragmatic Markers in English*. Mouton de Gruyter.
- Croft, W. (2001). *Radical Construction Grammar*. Oxford University Press.
- De Swart, H. (1998). Aspect shift and coercion. *Natural Language & Linguistic Theory* 16(2), 347-385.
- Fauconnier, G. & Turner, M. (2002). *The Way We Think: Conceptual Blending and the Mind's Hidden Complexities*. Basic Books.
- Fraser, B. (1999). What are discourse markers? *Journal of Pragmatics* 31, 931-952.
- Goldberg, A. E. (1995). *Constructions: A Construction Grammar Approach to Argument Structure*. University of Chicago Press.
- Goldberg, A. E. (2006). *Constructions at Work: The Nature of Generalization in Language*. Oxford University Press.
- Groom, N. (2019). Construction Grammar and the corpus-based analysis of discourses. *International Journal of Corpus Linguistics* 24(3), 291-323.
- Hasebe, Y. (2015). Design and Implementation of an Online Corpus of Presentation Transcripts of TED Talks. *Procedia - Social and Behavioral Sciences* 198, 174-182. <https://doi.org/10.1016/j.sbspro.2015.07.434>
- Hasebe, Y. (2021). An Integrated Approach to Discourse Connectives as Grammatical Constructions. PhD dissertation, Kyoto University.
- Hasebe, Y. (2023). Monadic Chat: A framework for maintaining context with text completion APIs. In *Proceedings of the 29th Annual Meeting of the Association for Natural Language Processing*, 3138-3143. [In Japanese]
- Hasebe, Y. & Lee, J. (forthcoming). Divergent strategies in text simplification: A comparative analysis of AI and human approaches in language processing. *Intercultural Pragmatics*.

References

- Lakoff, G. & Johnson, M. (1980). *Metaphors We Live By*. University of Chicago Press.
- Langacker, R. W. (2008). *Cognitive Grammar: A Basic Introduction*. Oxford University Press.
- Michaelis, L. A. (2004). Type shifting in construction grammar: An integrated approach to aspectual coercion. *Cognitive Linguistics* 15(1), 1-67.
- Pustejovsky, J. (1995). *The Generative Lexicon*. MIT Press.
- Redeker, G. (1990). Ideational and pragmatic markers of discourse structure. *Journal of Pragmatics* 14(3), 367-381.
- Schiffrin, D. (1987). *Discourse Markers*. Cambridge University Press.
- Sweetser, E. (1990). *From Etymology to Pragmatics*. Cambridge University Press.
- Traugott, E. C. (2022). *Discourse Structuring Markers in English: A Historical Constructionalist Perspective on Pragmatics*. John Benjamins.
- Traugott, E. C. & Trousdale, G. (2013). *Constructionalization and Constructional Changes*. Oxford University Press.
- Petricek, T. (2018). What we talk about when we talk about monads. *The Art, Science, and Engineering of Programming* 2(3), <https://programming-journal.org/2018/2/12/>.
- Wadler, P. (1995). Monads for functional programming. In Rogardt Haldal, Carsten Kehler Holst & Philip Wadler (eds.), *Advanced functional programming*, 24–52. Springer.

Corpus: TED Corpus Search Engine (TCSE) <https://yohasebe.com/tcse/>

Thank You!

Questions and Comments Welcome

Yoichiro Hasebe

Doshisha University

E-mail: yhasebe@mail.doshisha.ac.jp

GitHub: <https://github.com/yohasebe>